

Development of a Flow through Photo-Reactor to Study Degradation of Organic Compounds by Sequential Injection Analysis (SIA)

Allan C. V. dos Santos and Jorge C. Masini*

Instituto de Química, Universidade de São Paulo, CP 26077, 05513-970 São Paulo-SP, Brazil

Este trabalho descreve um foto-reator para a execução "in line" da degradação de compostos orgânicos através da reação de foto-Fenton, utilizando-se de um sistema de Análise por Injeção Sequencial (SIA). Uma solução do corante do sal tetrassódico de ácido 3,4',4'',4'''-tetrassulfônico de ftalocianina de cobre foi empregada como modelo da família das ftalocianinas, cujos pigmentos apresentam grande utilização na indústria de tintas automotivas. Baseando-se em testes preliminares, uma remoção de cor de 97% foi obtida em uma solução contendo 20 $\mu\text{mol L}^{-1}$ deste corante.

This work describes a photo-reactor to perform in line degradation of organic compounds by photo-Fenton reaction using Sequential Injection Analysis (SIA) system. A copper phthalocyanine-3,4',4'',4'''-tetrasulfonic acid tetrasodium salt dye solution was used as a model compound for the phthalocyanine family, whose pigments have a large use in automotive coatings industry. Based on preliminary tests, 97% of color removal was obtained from a solution containing 20 $\mu\text{mol L}^{-1}$ of this dye.

Keywords: photo-Fenton reactor, sequential injection analysis, wastewater, copper phthalocyanine dye, automotive coatings industry.

Introduction

Oxidative destruction of chemicals provides ultimate solutions for the treatment of hazardous wastes¹. Advanced Oxidative Processes (AOP's) are based on the generation of the hydroxyl radical, $\cdot\text{OH}$, a species that acts as a strong oxidant to a wide variety of organic and inorganic compounds². A special kind of AOP is the Fenton reaction,³ in which the hydroxyl radical is formed from the reaction between H_2O_2 and Fe(II) ions. This reaction can also be processed under influence of ultraviolet radiation, leading to the so-called photo-Fenton reaction. The Fenton and related reactions are viewed as potentially convenient and economical ways to generate oxidizing species for treating chemical wastes; compared to other bulk oxidants, hydrogen peroxide and iron are inexpensive, safe, and environmentally friendly⁴. AOP's are particularly interesting for non-biodegradable compounds that can be recalcitrant and/or toxic to microorganisms⁵.

Flow techniques are being consolidated as powerful tools for the routine control of parameters in various samples of environmental origin⁶. Sequential Injection

Analysis (SIA), a flow technique proposed by Ruzicka and Marshall,⁷ can be used to perform experiments necessary for the optimization of industrial processes⁸. The purpose of this paper is to describe an UV reactor specifically designed to study photo-Fenton reactions with a SIA system. A solution of copper phthalocyanine dye was used as a model compound for the phthalocyanine family, whose pigments may be present in effluents of automotive coatings industry.

Experimental

Reagents

All reagents were of analytical grade and the working solutions were prepared in deionized water obtained from a Simplicity 185 system from Millipore coupled to an UV lamp (Millipore, São Paulo, SP, Brazil).

Copper phthalocyanine dye, specifically copper phthalocyanine-3,4',4'',4'''-tetrasulfonic acid tetrasodium salt, molecular formula $\text{C}_{32}\text{H}_{12}\text{CuN}_8\text{O}_{12}\text{S}_4\cdot 4\text{Na}$ (CAS 123439-80-5) and molar mass of 984.25 g mol^{-1} was acquired from Sigma (Sigma-Aldrich Brazil, São Paulo, SP). A 40 $\mu\text{mol L}^{-1}$ solution of the dye was prepared only

*e-mail: jcmasini@iq.usp.br

by dilution of the salt with deionized water, adjusting the pH to 2.5 by adding HNO_3 .

Iron sulfate solution was prepared by dissolving $\text{FeSO}_4 \cdot 7\text{H}_2\text{O}$ salt with deionized water and HNO_3 to obtain a final concentration of $80 \mu\text{mol L}^{-1}$ (pH 2.5) and then purged with N_2 and protected from atmospheric O_2 , thus avoiding rapid oxidation of Fe(II).

Hydrogen peroxide solution at concentration of 0.5 mmol L^{-1} was prepared by direct dilution of commercial stock solution with deionized water and HNO_3 to a final pH of 2.5.

Apparatus and procedure

Reactor design

The photo-reactor used in the experiments reported herewith was designed in the author's laboratory and the steel structure was manufactured under request by SCA Serviços e Caldeiraria (Ribeirão Pires, SP, Brazil). Figure 1A presents the cover (lid) portion of the reactor and Figure 1B describes the body of the reactor, both made of steel. Basically, a mercury lamp is introduced in the center of the lid hole; more precisely, a 9 cm long quartz bulb of a high pressure mercury vapour source obtained from a common street lightning fluorescent lamp (Osram HQL E40, 400 W) by cutting and removing the larger external fluorescent bulb. Similar use of street lamps for a FIA reactor was already reported by Cavicchioli and Gutz⁹. An "U" shaped quartz tube (0.4 cm o.d., 0.3 cm i.d., 35 cm height) was placed inside both cylindrical paths of the cover. Placement of 5 cm of the tube over the lid base allows connection with SIA/detector tubes; the remaining of the tube (30 cm) is positioned inside the illuminated area of the reactor. Two Tygon tubes of distinct internal diameters allowed the connection of the 0.8 mm i.d. Teflon (PolyTetraFluoroEthylene, PTFE) tube from the SIA system to the reactor and from the reactor to the flow cell of the spectrophotometer. The first Tygon tube (0.3 cm o.d., 0.1 cm i.d., 1.3 cm length) is partially inserted (0.3 cm) on the second Tygon Tube (0.4 cm o.d., 0.3 cm i.d., 2.3 cm length) and acts as an intermediate connection. This is necessary because it was empirically observed that a direct connection of a low i.d. PTFE tube to a large i.d. quartz tube leads to air bubbles disruption. Changing the internal diameter (with Tygon connections) and after changing the character of the walls (hydrophobic/hydrophilic), however, leads to stable air bubbles for a wide range of air plugs and flow rates.

An electric fan (Roxline cooler 065.0004.90006) was fitted to the base of the reactor to force air circulation from its bottom, exiting through the curved slit at the

cover, and keeping a stable temperature near the quartz tube region.

Externally, the reactor was coated with a commercial low gloss black primer. Because the internal reactor walls are very reflective, the final internal portion of reactor body (from the fan area to the initial curvature of the reactor base) was also coated with the primer to reduce UV scattering to the environment. Figure 2 shows images of the cover apparatus (Fig. 2A) and the reactor final assembly (Fig. 2B).

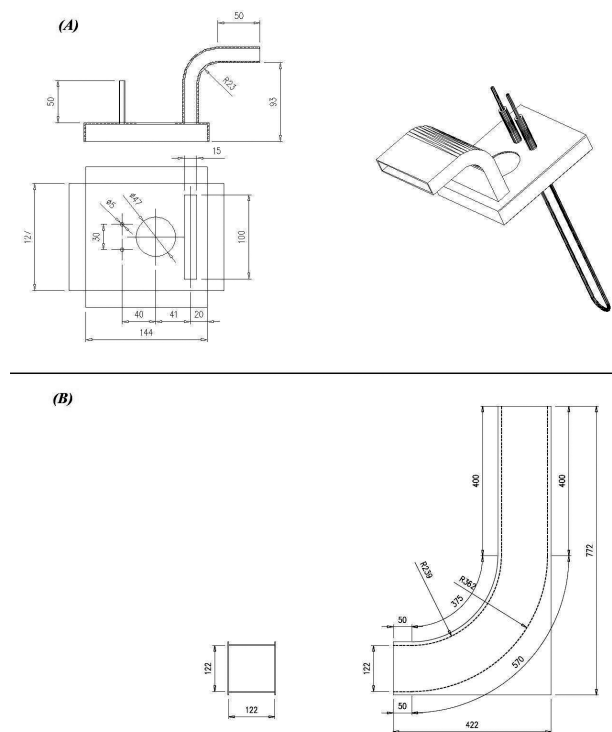

Figure 1. Photo-reactor project description. All values are in millimeters. A - Reactor cover. B - Reactor body.

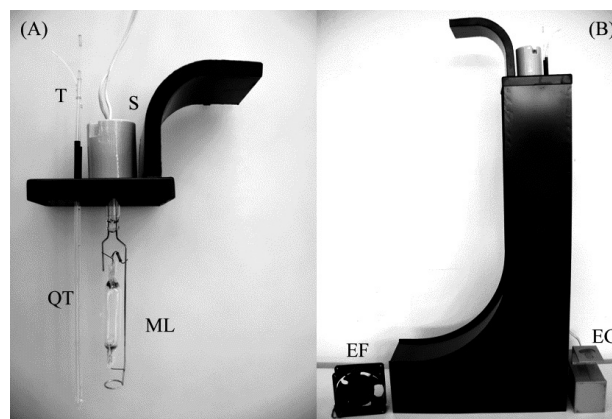

Figure 2. Photo-reactor images. (A) Cover apparatus with quartz tube (QT), mercury street lamp without bulb (ML), Tygon (T) connections and lamp socket (S). (B) Final reactor assembly showing lamp electric control gear (EG) and electric fan (EF) out of the reactor body for clarity.

SIA manifold

A FIALab 3500 system (FIALab Instruments, Bellevue, WA, USA) was used in the sequential injection mode according to Figure 3. Solutions were driven by a 5.00 mL syringe pump, SP, and an eight port rotary valve, RV (Valco Instrument Co., Houston). The holding coil, HC, was made of 3 m of 0.8 mm i.d. Teflon (PolyTetraFluoroEthylene, PTFE) tubing. Connection from the reactor to the flow detection cell was 53.5 cm long; connection from port 1 to the reactor was 42 cm long; both were made of 0.8 mm i.d. PTFE tubing. All other tubing connections were made of 0.8 mm i.d. PTFE tubing and PTFE nuts and ferrules (Upchurch, Oak Harbor, WA, USA). A Micronal B382 spectrophotometer (Micronal, São Paulo, SP, Brazil) was used as detector fitted to a 10 mm light path length flow cell with 80 μL of internal volume from Hellma (Hellma GmbH & Co. Mülheimheim, Baden, Germany), performing absorbance measurements at 632 nm. Spectral curve was previously obtained in a Hitachi spectrophotometer model U-3000 using a quartz batch cell of 10 mm optical path length.

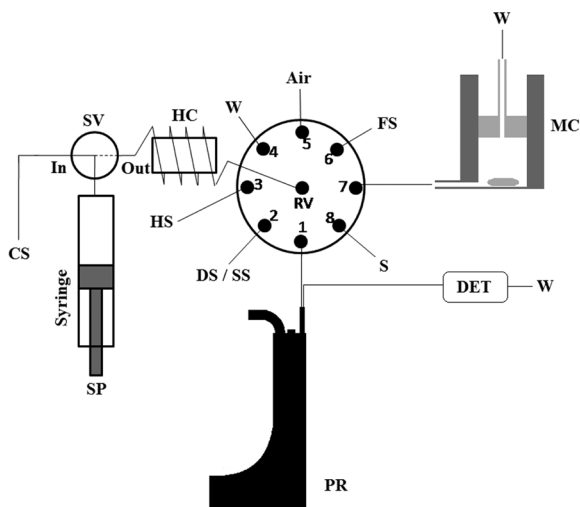

Figure 3. Sequential Injection Analysis (SIA) manifold for photo-Fenton studies. SP = Syringe pump; SV = selection valve for “in” and “out” positions of the system; HC = holding coil (3 meters long, 0.8 mm of internal diameter); CS = carrier solution (deionized water); DET = spectrophotometric detector; MC = mixing chamber (acrylic, with adjustable internal volume) containing magnetic stirrer; FS = $80 \mu\text{mol L}^{-1}$ FeSO_4 solution; HS = 0.50 mmol L^{-1} H_2O_2 solution; W = waste; PR = photo-reactor (connections to power supply not shown); SS = phthalocyanine standard solutions (calibration mode); DS = dilution solution (diluted HNO_3 - pH 2.5); S = $40 \mu\text{mol L}^{-1}$ phthalocyanine solution. All solutions (except carrier) were adjusted to pH 2.5 with HNO_3 .

The SIA system starts the on line sampling of solutions using the monosegmented flow analysis approach¹⁰. Monosegments aspirated to the holding coil are directed to a mixing chamber for homogenization. Sample, reagents and diluted HNO_3 are mixed to give a final solution

containing $20 \mu\text{mol L}^{-1}$ of phthalocyanine at pH 2.5, $140 \mu\text{mol L}^{-1}$ of H_2O_2 and $14 \mu\text{mol L}^{-1}$ of FeSO_4 . Another 1.0 mL monosegment containing the reaction mixture of the mixing chamber is aspirated by the SIA system and then pumped toward the photo-reactor and stopped for degradation. After the irradiation time, the monosegment is driven to the spectrophotometer for absorbance reading under stopped flow conditions on the ‘plateau’ between the two sharp peaks generated by the air bubbles passing through the detector. Cleaning of the manifold is performed automatically by the SIA equipment by pumping the carrier (deionized water) through the system.

Results and Discussion

General performance of photo-reactor

The temperature profile and time for temperature stabilization of the photo-reactor were studied before performing the blue dye degradation. Using an I.R. thermometer and measuring the reactor wall temperature after 20 min it was possible to define the temperature profile (Figure 4); by measuring the temperature time dependence of the hottest region (12 cm below the cover), it was observed that the equipment can reach a stable temperature profile after 15 min (stabilization time) as shown in Figure 5.

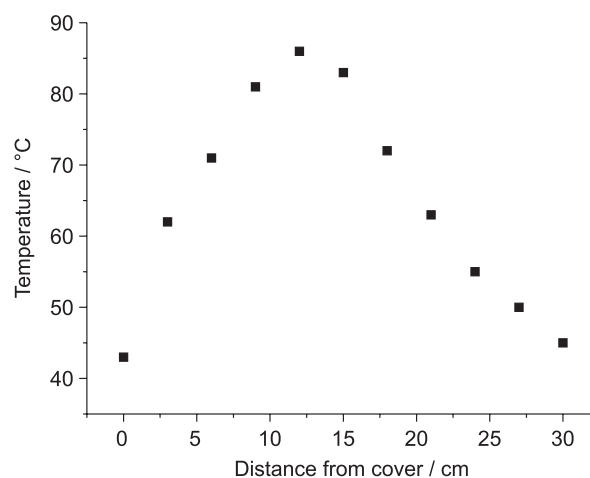
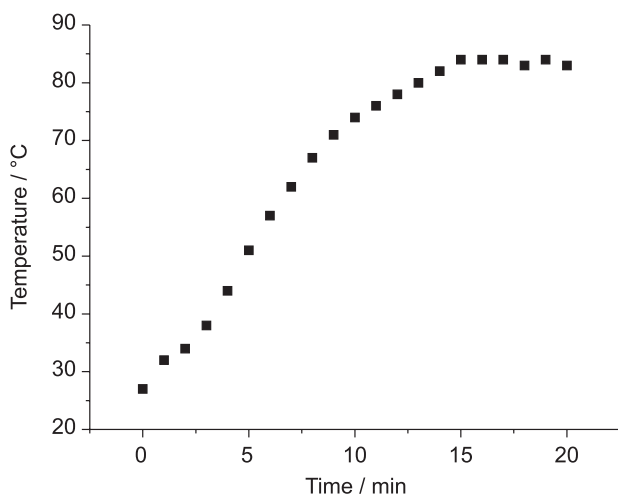

Figure 4. Temperature profile at the walls of the reactor after 20 min of operation. Distance is measured from the cover to the base of the reactor body.

Measurement with an ordinary mercury thermometer of water temperature exiting the reactor showed that the system can reach temperature equilibrium between carrier and equipment in less than 15 s. This fast equilibration time is possible due to the high area / volume ratio of the quartz tube. Water temperature was found to be around $60 \text{ }^\circ\text{C}$,

Table 1. Experimental conditions employed to evaluate the effect of the photo-reactor on decolorization of phthalocyanine blue

Experiment	Experimental Conditions	Stopped Flow in Photo-Reactor / s	Mean absorbance of the monosegment
1	Photo-reactor off; No Fenton reagent added	0	0.67 ± 0.02
2	Photo-reactor off; Fenton reagent added	0	0.61 ± 0.01
3	Photo-reactor on; Fenton reagent added	15	0.05 ± 0.01
4	Photo-reactor on; Fenton reagent added	30	0.02 ± 0.01

**Figure 5.** Temperature profile dependence with time monitored 12 cm below the reactor cover (at the walls of the reactor).

corresponding to approximately the mean temperature in the reactor path (65 °C).

Copper phthalocyanine dye degradation

Until entrance to the photo-reactor, the solution kept its original blue color, that is, the exposure time of the sample to the $\cdot\text{OH}$ radical generated in the Fenton reaction was not enough to start a significant color reduction of the dye. Four experiments were performed using a $20 \mu\text{mol L}^{-1}$ dye solution under distinct experimental conditions as detailed in Table 1. Results are graphically summarized in Figure 6. Phthalocyanine dye has a linear absorbance range from 1.0 to $10 \mu\text{mol L}^{-1}$; thus the original solution signal height (experiments #1 and #2) should be about 1.2 times higher than the observed height due to linearity loss. The purpose of the first two experiments is to show that UV irradiation is the main factor involved in color removal of the solution (experiments #3 and #4). Fenton reaction alone (experiment #2) caused a slight reduction in the color of the original solution, but it was not efficient under analysis time. A very strong decrease of the analytical signal is observed when the photo-reactor is operating; if a low concentration of the dye solution (below $20 \mu\text{mol L}^{-1}$) was used, the detector could not be

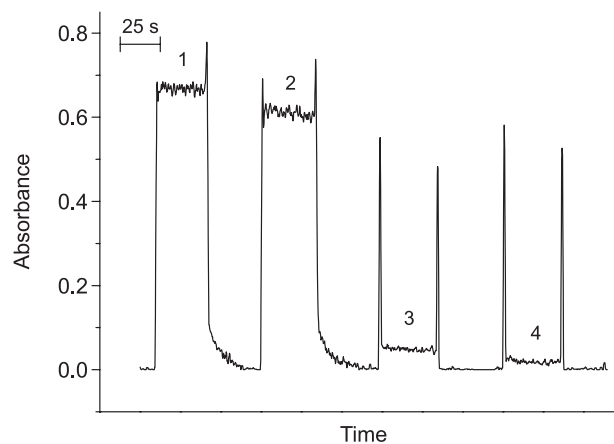
**Figure 6.** Grouped records of absorbance from tests of the photo-reactor on the degradation of $20 \mu\text{mol L}^{-1}$ phthalocyanine blue dye solutions (from left to the right): (1) phthalocyanine solution with photo-reactor "off"; (2) – Fenton reaction mixture without UV irradiation; (3) – Fenton reaction mixture exposed to UV irradiation under 15 s of stopped flow period; (4) – Fenton reaction mixture exposed to UV irradiation under 30 s of stopped flow period.

able to register any signal from the remaining dye under operational conditions. Considering the calibration curve, the color removal percentage reached 97%.

Conclusions

Preliminary tests have shown that the proposed photo-reactor could be used to study the degradation of matrices by the photo-Fenton reaction. It also suggests an industrially feasible pre-treatment process because fast color removal was achieved in a very short period of time, a feature that would not be possible by using only direct biological treatments¹¹. Future works will show detailed study for phthalocyanine blue dye and how to get fast and reliable optimization of the degradation conditions with SIA manifolds.¹²

Acknowledgements

The authors are grateful to FAPESP and CNPQ for the financial support. We are also grateful to Carlos Eduardo Rodrigues da Silva and Juilson Nonato Machado da Silva for kindly helping to coat the photo-reactor.

References

1. Huang, C. P.; Dong, C.; Tang, Z.; *Waste Manage.* **1993**, *13*, 361.
2. Nogueira, R. F. P.; Trovó, A. G.; da Silva, M. R. A.; Vila, R. D.; *Quim. Nova* **2007**, *30*, 400.
3. Fenton, H. J. H.; *J. Chem. Soc.* **1894**, *65*, 899.
4. Pignatello, J. J.; Oliveros, E.; MacKay, A.; *Crit. Rev. Environ. Sci. Technol.* **2006**, *36*, 1.
5. Raj, C. B. C.; Quen, H. L.; *Chem. Eng. Sci.* **2005**, *60*, 5305.
6. Miró, M.; Hansen, E. H.; *Trends Anal. Chem.* **2006**, *25*, 267.
7. Ruzicka, J.; Marshall, G. D.; *Anal. Chim. Acta* **1990**, *237*, 329.
8. dos Santos, A. C. V.; Masini, J. C.; *Talanta* **2009**, *77*, 1081.
9. Cavicchioli, A.; Gutz, I. G. R.; *Anal. Chim. Acta* **2001**, *445*, 127.
10. Pasquini, C.; Oliveira, W. A.; *Anal. Chem.* **1985**, *57*, 2575.
11. Martínez, N. S. S.; Fernández, J. F.; Segura, X. F.; Ferrer, A. S.; *J. Hazard. Mater.* **2003**, *B101*, 315.
12. dos Santos, A. C. V.; Masini, J. C.; *Microchem. J.* **2009**, *93*, 110.

Received: December 8, 2008

Web Release Date: October 9, 2009

FAPESP helped in meeting the publication costs of this article.