

An experimental verification of Newton's second law

(Uma verificação experimental da segunda lei de Newton)

Roberto Hessel¹, Saulo Ricardo Canola, Dimas Roberto Vollet

Departamento de Física, IGCE, UNESP, Caixa Postal 178, 13506-900, Rio Claro, SP, Brazil

Recebido em 6/7/2012; Aceito em 11/2/2013; Publicado em 24/4/2013

Descrevemos nesse trabalho um procedimento experimental para investigar a validade da segunda lei de Newton. A montagem experimental utilizada permite acelerar um carrinho sobre um trilho de ar por meio de forças constantes e conhecidas. Mostramos também como determinar a aceleração a partir de velocidades médias calculadas para intervalos de tempo sucessivos do movimento usando vários contadores eletrônicos conectados a um único circuito oscilador a cristal. Dentro dos erros experimentais, os experimentos realizados mostram claramente a proporcionalidade entre aceleração e força para uma massa constante e entre aceleração e o inverso da massa para uma força constante.

Palavras-chave: segunda lei de Newton, medida de intervalo de tempo, medida de aceleração, velocidade média.

We describe an experimental procedure to probe the validity of Newton's second law. The experimental arrangement allows us to accelerate a glider on an air track by means of forces that are both steady and known. We also show how to determine acceleration from average speeds calculated for successive time intervals of the motion measured by using several electronic counters connected to a single-crystal oscillator circuit. Within experimental errors, the experiments clearly show the proportionality between acceleration and force for a fixed mass and between acceleration and inverse of mass for a fixed force.

Keywords: Newton's second law, measurement of time interval, measurement of acceleration, average speed.

1. Introduction

To introduce Newton's second law or concepts such as force, inertial and gravitational mass and weight, it is a common practice to use the approach offered by PSSC Physics that, according to Arons [1], is quite reasonable for introductory levels. In the PSSC context, Newton's second law of motion is investigated in the laboratory, with carts, times, and a rubber loop stretched a constant amount as the unit of force [2]. The choice of stretched elastics to accelerate a cart on a level table is quite suitable as the starting point because it takes into account the intuitive notion of force related to a sensation of muscular effort but, due to the difficulty of keeping the rubber loop stretched a constant amount as the cart accelerates, the quantitative results are not always convincing. Indeed, only the more attentive pupils obtain satisfactory results [3]. For this reason, when we follow the sequence outlined in PSSC, we complement the laboratory activity with an experimental demonstration that allows confirmation of the validity of Newton's se-

cond law in a quick and convincing way.

2. Experimental set-up

The experimental set-up consists of a glider on an air track connected by a string passing over a small pulley to a hanging load of mass m and weight mg . We consider the glider and the load as a single object, subject to the accelerating force mg . To show that the acceleration of the system is proportional to the acceleration force when the total mass is kept constant, we begin with a hanging load of mass m and add four identical metallic discs of mass m to the glider of mass M (Fig. 1) Therefore, the accelerating force mg acts on a system of total mass $M + 5m$. To double the accelerating force, one disc is transferred from the glider to the hanging load. To triple the force, two discs are transferred from the glider to the hanging load, and so on [4]. To show that the acceleration of the system is inversely proportional to its mass when the accelerating force is kept constant,

¹E-mail: fisica@rc.unesp.br.

we change the mass of the system by loading the glider with mass of different sizes or connecting another glider to the original.

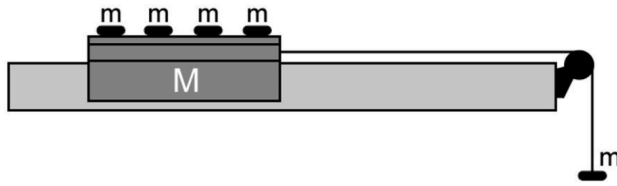

Figure 1 - A simplified drawing of the air track showing the hanging load and the glider loaded with metallic discs.

The acceleration can be determined from the average speeds calculated for successive time intervals of the motion. For a question of availability and cost, we have measured time intervals by using electronic counters in conjunction with a single-crystal oscillator circuit operating at 1 kHz and a photogate [5]. The timing circuit is shown in Fig. 2.

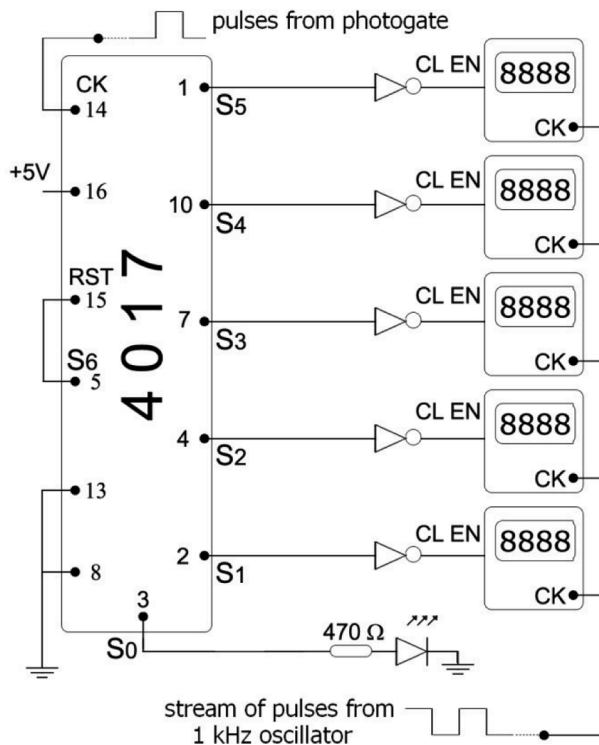

Figure 2 - The timing circuit.

The counters have two inputs: the clock (CK) and the clock enable (CL EN). The first receives the rectangular pulses sent by the oscillator and the other enables the counting process when it is held at ground state. When the logic state at this input is high, the counting stops. The heart of the circuit is the 4017. The 4017 is a decade counter with ten outputs that go to HIGH (H) in sequence when a source of pulses is connected to the clock input and when suitable logic levels are applied to the reset and enable inputs [6,7].

Briefly, the electronic circuit (Fig. 2) works as follows. If the logic state at the S_0 output is initially H,

the S_1, S_2, \dots, S_5 outputs are LOW (L) and the state at each CL EN input is H due to the presence of the NOT gate. Consequently, all counters are blocked because an H level on the CL EN input inhibits the clock's operation. When the clock's input of the 4017 receives the first pulse, the high state is transferred from S_0 to S_1 and the first counter starts the timing. When the second pulse arrives, the state at S_1 changes from H to L and S_2 goes to H. Then, the first counter stops the timing and the second starts. Finally, when the sixth pulse arrives, S_5 goes from H to L and the fifth counter stops the timing, while S_0 goes to H again (shining LED) because the S_6 output is connected directly to reset input.

The pulses that arrive at the clock's input of the 4017 are generated during the passage of posts transported by the glider through a photogate. The glider carries six posts, evenly spaced on a wooden ruler fixed to it (Fig. 3).

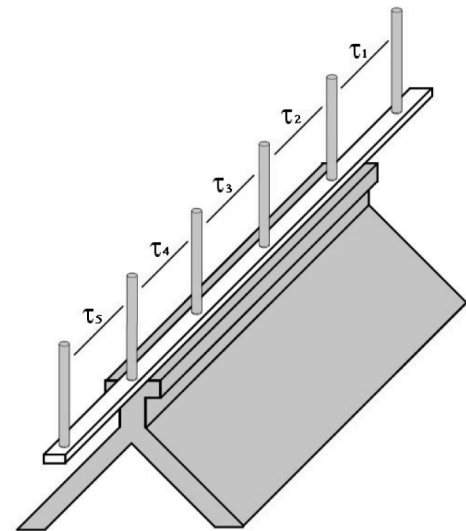

Figure 3 - A simplified drawing of the glider carrying six evenly spaced posts.

So, after the posts have passed through the photogate, the counters record, in ms, the time intervals $\tau_1, \tau_2, \dots, \tau_5$ indicated in Fig 3. If the distance between successive posts is d , the average speed of the glider in the time interval τ_1 is $\bar{v}_1 = d/\tau_1$, in τ_2 is $\bar{v}_2 = d/\tau_2$, etc. The set of these values may provide information regarding the motion of the glider.

3. Analysis of the data

Consider the expression $\bar{v} = \frac{1}{\Delta t} \int_{t_1}^{t_2} v dt$, where $\Delta t = t_2 - t_1$. Expanding the integrand into a Taylor series about $t = \bar{t}$ [8], *i.e.* about the midpoint of the interval, we obtain

$$\bar{v} = \frac{1}{\Delta t} \int_{\bar{t}-\Delta t/2}^{\bar{t}+\Delta t/2} \left[v(\bar{t}) + a(\bar{t})(t-\bar{t}) + \frac{1}{2!} \dot{a}(\bar{t})(t-\bar{t})^2 + \dots \right] dt, \quad (1)$$

where $a(\bar{t}) = \left. \frac{dv}{dt} \right|_{t=\bar{t}}$, $\dot{a}(\bar{t}) = \left. \frac{d^2v}{dt^2} \right|_{t=\bar{t}}$ and so on.

Setting $\tau = t - \bar{t}$ and integrating the series term by term, the Eq. (1) can be written as

$$\bar{v} = v(\bar{t}) + \frac{a(\bar{t})}{\Delta t} \cdot \frac{\tau^2}{2} \Big|_{-\Delta t/2}^{\Delta t/2} + \frac{1}{2} \frac{\dot{a}(\bar{t})}{\Delta t} \cdot \frac{\tau^3}{3} \Big|_{-\Delta t/2}^{\Delta t/2} + \dots \quad (2)$$

The terms in τ^2 , τ^4 , ... are all zero, so that the Eq. (2) reduces to

$$\bar{v} = v(\bar{t}) + \frac{1}{2} \dot{a}(\bar{t}) \frac{(\Delta t)^2}{12} + \frac{1}{24} \ddot{a}(\bar{t}) \frac{(\Delta t)^4}{80} + \dots \quad (3)$$

By inspection of Eq. (3), we conclude immediately that, for constant acceleration a , $\bar{v} = v(\bar{t})$; a well-known result. But the converse is also true: if for any Δt , $\bar{v} = v(\bar{t})$, then the acceleration a must be constant [8]. In fact, if $\bar{v} = v(\bar{t})$ for any Δt , the sum of the terms in $(\Delta t)^2$, $(\Delta t)^4$, ... at the right side of the Eq. (3) must be zero for any Δt . This condition is fulfilled if and only if $\dot{a}(\bar{t}) = \ddot{a}(\bar{t}) = \dots = 0$, which only happens when a is constant. So, to analyze the motion of the glider, we assume initially that $v(\bar{t}) = \bar{v}$ for any Δt . If this is true, then the graph of $v(\bar{t})$ versus t is linear and the slope of the straight line is the acceleration of the glider.

Evidently, the acceleration can also be obtained by analyzing the distance traveled by the glider as a function of time [9], but, in view of the definition of acceleration, we prefer to use the method described above because it involves change in speed and time interval.

4. Applications

4.1. Experiment 1 - Relation between acceleration and accelerating force for constant total mass

The glider shown in Fig. 3 was loaded with four metallic discs having a mass of 50 g each and was connected to a hanging load, also weighing 50 g, by a string passing over a small pulley. The system (glider + hanging load) with mass 1502 g was then released. At the end of the run, the counters recorded the time intervals τ_1 , τ_2 , ... τ_5 . Afterwards, one of the discs transported by the glider was transferred to the hanging load and the procedure above was repeated. We carried out the

same thing with the remaining discs. The time intervals recorded on the counters after each run are shown in Table 1.

Tabela 1 - Time intervals recorded on the counters for five hanging loads.

Hanging load (g)	Δt (ms)				
	τ_1	τ_2	τ_3	τ_4	τ_5
50	406	297	245	214	193
100	292	212	175	152	136
150	242	173	142	124	111
200	220	154	126	109	97
250	159	122	103	92	82

Knowing that the distance between two consecutive posts is 12.00 cm, we can determine the average speed of the glider at each time interval.

For instance, Table 2 shows the average speed calculated for the first run.

Tabela 2 - Average speeds calculated in five successive time intervals for a hanging load of 50 g.

Δt (ms)	$t = \bar{t}$ (ms)	\bar{v} (cm/s)
406	203	29.6
297	554.5	40.4
245	825.5	49.0
214	1055.5	56.1
193	1258.5	62.2

In Fig. 4 we have drawn \bar{v} versus t (dashed line) and $v(\bar{t})$ versus t (solid line), assuming that $v(\bar{t}) = \bar{v}$. As all points corresponding to $v(\bar{t}) = \bar{v}$ lie on the straight line, the acceleration of the glider is constant and is given by the slope of this line.



Figura 4 - Speed-versus-time curves for a system (glider + hanging load), subject to a constant force. The dashed line refers to the average speed \bar{v} whereas the solid line refers to the instantaneous speed $v(\bar{t})$ at the midpoint of each time interval. Linear fit: $v = 23.28 + 30.99 \times 10^{-3} t$ with t in ms.

Proceeding in the same way with the remaining rows in Table 1, we can determine the acceleration for the other runs. Figure 5 shows the acceleration a as a function of the hanging load mass m_{hl} . As expected, the graph tells us that for a fixed mass, a is proportional to m_{hl} or the acceleration force since the weight (acceleration force) acting on the load is proportional to its

mass. The fact that the straight line crosses the force axis slightly to the right of the origin can be attributed to the presence of friction forces. Using $g = 976 \text{ cm/s}^2$, the mass of the system, $(\text{slope of straight line}/g)^{-1}$, is equal to 1518 g. This value is in reasonable agreement with the value 1502 g measured.

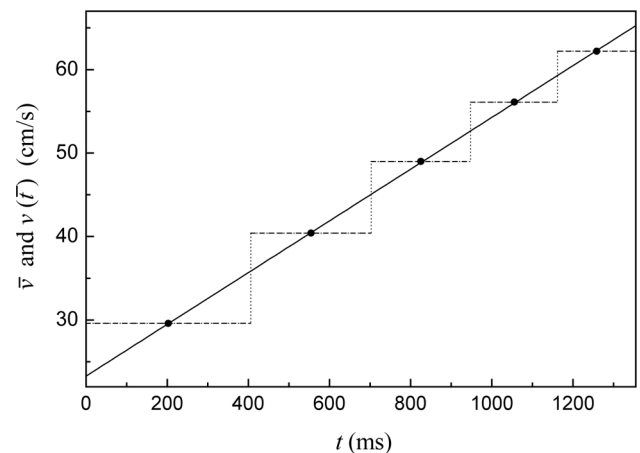
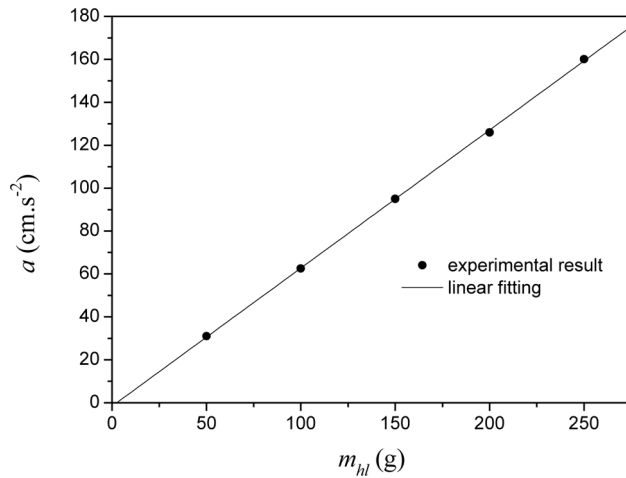

Figure 5 - Acceleration of the system (glider + hanging load) as a function of the hanging load for a system of constant mass. Linear fit: $a = -1.594 + 0.643 m_{hl}$.

4.2. Experiment 2 - Relation between acceleration and mass for a constant accelerating force

This experiment was done using two gliders; one of them having a length of 24.7 cm and the other 37.5 cm. They were used either coupled together or separately. To increase the mass of the system, we also fastened metal bars to both sides of the gliders (Fig. 6).

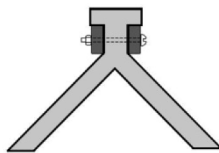

Figure 6 - Air track glider with metal bars fastened to both sides of the glider.

The mass of the hanging load was fixed at 100 g. Table 3 shows the total mass m_T used for each run and the corresponding acceleration a .

Tabela 3 - Mass of the system (glider + hanging load) and the corresponding acceleration for a hanging load of 100 g.

m_T (g)	a (cm/s ²)
593.3	160.9
791.7	117.3
941.9	98.9
1502	62.6
1878	50.3

As expected, the graph of acceleration a versus $1/m_T$ (Fig. 7) shows that a is inversely proportional to

m_T when the acceleration force is kept constant. The slope of the straight line, equal to 9.53×10^4 dynes, corresponds to the acceleration force. Within experimental error, the agreement between this value and the one calculated ($100 \text{ g} \times 976 \text{ cm/s}^2 = 9.76 \times 10^4$ dynes) is very satisfactory.

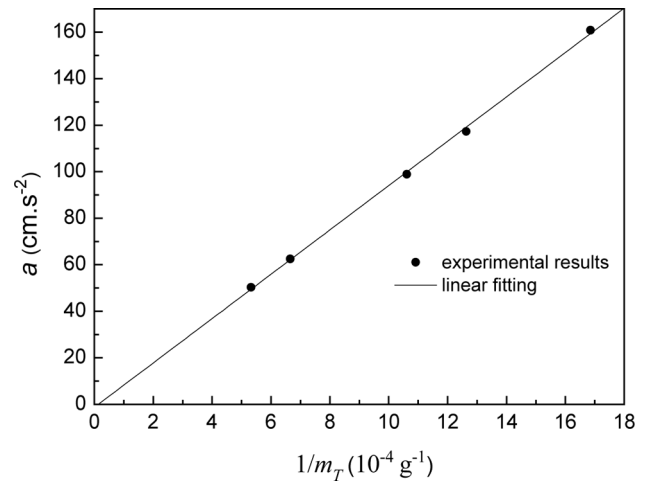

Figure 7 - Acceleration versus the inverses of the system's mass for a constant accelerating force. Linear fit: $a = -1.26 + 9.53 \times 10^4 m_T^{-1}$.

5. Conclusions

We have described a way of showing effectively and quickly the proportionality between acceleration and force for a fixed mass and between acceleration and inverse of mass for a fixed force, as predicted by Newton's second law. In addition, the technique that we have used to determine the acceleration of the moving object affords a good opportunity to discuss certain questions concerning the average speed and instantaneous speed, which have little chance of being treated in a laboratory class. The experiments proposed are easy to perform and are appropriate for both undergraduate laboratories and demonstration in class lecture, since the students have already acquired some level of familiarity with basic concepts such as mass and weight.

Acknowledgement

The authors thank to Rosana A. Gonçalves Pesce for valuable discussions during the preparation of the manuscript.

Referências

- [1] A.B. Arons, *Teaching Introductory Physics* (John Wiley & Sons, Inc, New York, 1997), p. 65-66.
- [2] PSSC, Physical Science Study Committee, *Teacher's Resource Book and Guide Part III* (Heath, Boston, 1967), 2nd ed., Experiments III-1 and III-2.
- [3] H.S. Fricker, *Phys. Educ.* **29**, 386 (1994).

- [4] E.M. Rogers, *Physics For The Inquiring Mind* (Princeton University Press, New Jersey, 1973), p. 111.
- [5] R. Hessel, C.S. de Oliveira, G.A. Santarine e D.R. Vollet, *Revista Brasileira de Ensino de Física* **30**, 1501 (2008). Erratum: *Revista Brasileira de Ensino de Física* **31**, 4901 (2009).
- [6] See <http://www.doctrionics.co.uk/4017.htm>
- [7] R. Hessel, C.S. de Oliveira, G.A. Santarine, D.R. Vollet e A.C. Perinotto, *Revista Brasileira de Ensino de Física* **30**, 1502 (2008).
- [8] B. Denardo, S. Wong and A. Lo, *Am. J. Phys.* **57**, 528 (1989).
- [9] H. Cohen and D. Horvath, *Am. J. Phys.* **56**, 950 (1988).