



Identification of RAPD and SCAR markers associated with yield traits in the Indian tropical tasar silkworm *Antheraea mylitta* drury

Suhrid R. Dutta¹, Prasanta K. Kar², Ashok K. Srivastava², Manoj K. Sinha², Jai Shankar¹ and Ananta K. Ghosh¹

¹Department of Biotechnology, Indian Institute of Technology Kharagpur, Kharagpur, India.

²Central Tasar Research and Training Institute, Ranchi, India.

Abstract

The tropical tasar silkworm, *Antheraea mylitta*, is a semi-domesticated *vanya* silk-producing insect of high economic importance. To date, no molecular marker associated with cocoon and shell weights has been identified in this species. In this report, we identified a randomly amplified polymorphic DNA (RAPD) marker and examined its inheritance, and also developed a stable diagnostic sequence-characterized amplified region (SCAR) marker. Silkworms were divided into groups with high (HCSW) and low (LCSW) cocoon and shell weights, and the F₂ progeny of a cross between these two groups were obtained. DNA from these silkworms was screened by PCR using 34 random primers and the resulting RAPD fragments were used for cluster analysis and discriminant function analysis (DFA). The clustering pattern in a UPGMA-based dendrogram and DFA clearly distinguished the HCSW and LCSW groups. Multiple regression analysis identified five markers associated with cocoon and shell weights. The marker OPW16_{905 bp} showed the most significant association with cocoon and shell weights, and its inheritance was confirmed in F₂ progeny. Cloning and sequencing of this 905 bp fragment showed 88% identity between its 134 nucleotides and the Bmc-1/Yamato-like retroposon of *A. mylitta*. This marker was further converted into a diagnostic SCAR marker (SCOPW 16_{826 bp}). The SCAR marker developed here may be useful in identifying the right parental stock of tasar silkworms for high cocoon and shell weights in breeding programs designed to enhance the productivity of tasar silk.

Key words: *Antheraea mylitta*, quantitative trait, RAPD, SCAR marker, tasar silkworm.

Received: October 25, 2011; Accepted: May 21, 2012.

Introduction

The rearing of silkworm species of the families Bombycidae and Saturniidae is an age old practice that is an important part of the rural economy in India. The tropical tasar silkworm (*Antheraea mylitta*) produces tasar silk, otherwise known as *vanya* silk, that is famous for its luster, durability and uniqueness. Tasar silk fetches excellent price on the Indian domestic market and abroad. However, this silkworm occurs mainly in the wild, with only two races (Daba and Sukinda) being exploited for commercial egg production; both of these races are reared under semi-domestic conditions. Since this silkworm is heterogeneous (Suryanarayana and Srivastava, 2005), with a high level of heterozygosity (Kar *et al.*, 2005), the development of stable heterotic breeds or lines is difficult. Although conventional breeding techniques have been used to develop some breeds, none of them is suitable for widespread use by farmers. On the other hand, the need to improve the production of tasar silk and provide employment for poor farmers

requires the use of highly productive breeds of this silkworm. In this setting, the identification of molecular markers associated with yield traits is of immense importance.

In recent years, several types of molecular markers have been introduced into crop and animal improvement programs. Randomly amplified polymorphic DNA (RAPD) is a technique that has been used to construct a linkage map of the silkworm *Bombyx mori* (Williams *et al.*, 1990; Proboon *et al.*, 1995) and to generate a good number of morpho-biochemical markers (Tazima, 1964; Doira, 1978; Shi *et al.*, 1995; Nagaraju and Singh, 1997). In contrast, random fragment length polymorphism (RFLP) has been used to map food preference genes in *B. mori* while inter-simple sequence repeat (ISSR) markers have been used to establish the inheritance of yield traits (Keisuke *et al.*, 2007). Multiple regression analysis (MRA) has been the tool of choice for identifying markers associated with the main yield traits such as cocoon weight and shell weight (Chatterjee and Pradeep, 2003; Chatterjee and Mohandas, 2003). RAPD markers have also been used for linkage analysis of some phenotypical characters in plants, such as fruit skin color (Inoue *et al.*, 2006). Rapid progress has also been made in the development of RFLP-based quantitative trait

loci (QTL) mapping for the improvement of crop species such as pepper and tomato (McCouch *et al.*, 1997). DNA markers such as RFLP and RAPD linked to a specific yield trait have been widely explored and successfully used to improve target traits in crop plants and livestock (Tanksley *et al.*, 1989).

RAPD and sequence characterized amplified region (SCAR) markers have been used to identify ecoraces and estimate the genetic variability in tasar silkworms (Saha and Kundu, 2006; Saha *et al.*, 2008). The marked diversity and variation in these silkworms (Kar *et al.*, 2005) has made use of bulk segregation analysis to identify markers associated with yield traits a challenging task (Martin *et al.*, 1991; Michaelmore *et al.*, 1991). To date, no molecular studies have attempted to identify yield trait-specific markers in *A. mylitta*, although the availability of such markers would facilitate selection during directional molecular breeding and would improve our understanding of the molecular genetic phenomenon behind yield parameters and their proper genetic manipulation. In this report, we describe the first identification and inheritance pattern of an RAPD marker, along with the development of a stable diagnostic SCAR marker associated with two important yield parameters (cocoon weight and shell weight) in ecorace Daba of *A. mylitta*.

Materials and Methods

Tasar silkworm

Ecorace Daba of *A. mylitta* was used in this study. Two experimental groups were formed during diapause based on cocoon weight and shell weight. The high cocoon and shell weight group (HCSW) consisted of individuals with a cocoon weight > 11 g and a shell weight > 2 g whereas the low cocoon and shell weight group (LCSW) consisted of individuals with a cocoon weight < 10 g and shell weight < 1 g. In each group, care was taken to maintain the male:female ratio (55:45) that is characteristic of random populations of tasar silkworm. Initially, the size of each group was limited to 1000 and there were significant differences in the mean values for cocoon weight and shell weight ($p < 0.001$, Student's *t*-test). HCSW x LCSW crosses were undertaken during the first crop (July to August), also known as the seed crop. The larvae of both parental groups and crosses were reared on *Terminalia arjuna* using standard rearing practices. In the subsequent generation, the offspring were allowed to mate among themselves. In the second crop (September to November), also known as the commercial crop or the diapausing generation under Ranchi conditions, the parental combinations and F₂ progeny of the HCSW x LCSW cross were obtained. In the parental HCSW group the average cocoon weight was 14.52 ± 0.87 g and the shell weight was 2.53 ± 0.38 g. Similarly, in the parental LCSW group the cocoon and shell weights were 9.31 ± 0.35 g and 0.85 ± 0.23 g, respectively.

In the F₂ generation, the cocoon and shell weights were 11.52 ± 0.27 g and 1.53 ± 0.31 g, respectively. Random samples of these cocoons were used to obtain genomic DNA for molecular analysis.

DNA isolation and PCR for RAPD

Genomic DNA was isolated from the fat body tissue of individual pupae by a standard method (Sambrook *et al.*, 2003). Briefly, 0.2 g of fat bodies from individual pupae was ground in liquid nitrogen using a prechilled mortar and pestle and suspended in 10 mM Tris-HCl, pH 8.0, containing 100 mM NaCl, 25 mM EDTA and 0.5% SDS. The suspension was then digested with proteinase K (100 µg/mL) at 50 °C overnight and extracted with phenol:chloroform:isoamyl alcohol (25:24:1, v/v). RNA was removed by treatment with RNase A (100 µg/mL) at 37 °C for 30 min and DNA was precipitated with 2.5 volumes of ethanol. Finally, the DNA pellet was dissolved in TE buffer (10 mM Tris-HCl, 1 mM EDTA, pH 8.0) and quantified spectrophotometrically. The quality of the purified DNA was analyzed by electrophoresis in a 0.8% agarose gel and diluted to 5 ng/µL prior to use in the RAPD experiments.

DNA isolated from individual pupae of the HCSW and LCSW groups and F₂ progenies was initially screened by PCR with 34 random primers at the optimum annealing temperature and MgCl₂ concentration indicated in Table 1. RAPD-PCR for each DNA sample was done in triplicate, as described by Williams *et al.* (1990). The 25 µL reaction mixture contained 1X PCR buffer (Bioline), a variable concentration of MgCl₂ (2.0-2.5 mM), 100 µM dNTP mix, 0.2 µM primer, 0.75 U of *Taq* polymerase (Bioline) and genomic DNA (25 ng). The PCR was done using the following conditions: initial denaturation at 94 °C for 3 min, followed by 45 cycles of denaturation at 94 °C for 1 min, annealing at 36-42 °C for 1 min, and extension at 72 °C for 2 min, with a final extension at 72 °C for 7 min. The amplified products were electrophoresed in a 1.5% agarose gel, stained with ethidium bromide, visualized with a UV transilluminator and photographed with a Kodak EDAS 290 gel documentation system.

Cloning and sequencing of an HCSW-specific RAPD fragment

An amplicon (~900 bp) specific for the HCSW group (amplified by the primer OPW16) was excised from the agarose gel and eluted with a QIAquick gel extraction kit (QIAGEN) according to the manufacturer's protocol. The eluted DNA was cloned into the vector pTZ57R/T (MBI Fermentas), transformed in XL Blue *E. coli* cells and the recombinant clones were selected on LB agar plates containing ampicillin and tetracycline. Plasmid DNA was isolated from these recombinant bacteria and analyzed by digestion with *EcoRI* and *HindIII*. Plasmids harboring inserts of the proper size were sequenced using M13 forward and reverse

Table 1 - List of primers used for RAPD analysis and the resulting polymorphic DNA bands.

Primer	Sequence (5'-3')	Annealing temperature (°C)	MgCl ₂ (mM)	Total number of bands amplified	Number of polymorphic bands	Polymorphism (%)
OPA02	TGCCGAGCTG	36	2	101	101	100
OPA11	CAATCGCCGT	36	2	169	147	86.98
OPA13	CAGCACCCAC	38	2	39	17	43.58
OPA14	TCTGTGCTGG	36	2.5	142	142	100
OPA16	AGCCAGCGAA	36	2	76	54	71.05
OPA17	GACCGCTTGT	36	2.5	39	39	100
OPAJ03	AGCACCTCGT	36	2	92	92	100
OPAJ04	GAATGCGACC	36	2	94	72	76.6
OPAJ07	CCCTCCCTAA	36	2	121	77	63.63
OPAJ08	GTGCTCCCTC	36	2.5	163	141	86.5
OPAJ15	GAATCCGGCA	42	2	66	66	100
OPAJ17	ACCCCTATG	36	2	135	135	100
OPAJ19	CAAACGTCGG	36	2	153	131	85.62
HAP03	AAGCTTTGGTCAG	36	2	158	92	58.22
OPBC11	TTTTGCCCCC	38	2	101	57	56.43
OPBC12	CCTCCACCAG	42	2	100	78	78
OPBC20	AGCACTGGGG	38	2	63	41	65.07
OPC02	GTGAGGCGTC	36	2.5	139	95	68.34
OPC09	CTCACCGTCC	37	2	123	101	82.1
OPC10	TGTCTGGGTG	36	2	52	30	57.7
OPC12	TGTCATCCCC	36	2.5	49	27	55.1
OPC15	GACGGATCAG	38	2.5	85	85	100
OPC16	CACACTCCAG	36	2.5	126	104	82.53
OPC17	TTCCCCCAG	36	2	143	121	84.61
OPW4	CAGAAGCGGA	42	2	163	163	100
OPW5	GGCGGATAAG	39	2	57	35	61.4
OPW6	AGGCCCGATG	36	3	110	88	80
OPW9	GTGACCGAGT	37	2.5	61	39	63.93
OPW12	TGGGCAGAAG	42	2	149	127	85.23
OPW13	CACAGCGACA	36	2	77	33	42.85
OPW16	CAGCCTACCA	42	2	152	130	85.52
OPW17	GTCCTGGGTT	37	2	54	32	59.25
OPW18	TTCAGGGCAC	38	2.5	75	75	100
OPW20	TGTGGCAGCA	36	2.5	90	90	100

sequencing primers with a cycle sequencing kit (Big Dye^R Terminator 3.1, ABI) in an automated DNA sequencer (ABI Model 3100). The sequence was analyzed with the Sequencher program (Genecodes Corp.) and BLAST searches were used to identify homology with other sequences.

Development of diagnostic SCAR markers

A pair of specific forward and reverse primers (*Am*SCAR-F 5-TAGTGAAGGCGGCGTAGAGTAAGG GAG-3 and (*Am*SCAR-R 5-ACACTACACAAAGTACC AGCGACCCG-3), designed based on the sequence of the

HCSW fragment (OPW 16₉₀₅ bp) identified in the previous section, were used to amplify specific bands of genomic DNA from all individuals in the HCSW, LCSW and F₂ groups in order to convert the corresponding RAPD marker into a single locus sequence-characterized amplified region (SCAR) marker. PCR was done in a 25 µL reaction mixture containing 25 ng of genomic DNA, 2 mM MgCl₂, 1X PCR buffer (Bioline), 100 µM dNTP mixture, 0.2 µM primers and 1 U of *Taq* polymerase (Bioline) under the following conditions: initial denaturation at 94 °C for 3 min, followed by 35 cycles of denaturation at 94 °C for 1 min, annealing at

65 °C for 1 min and extension at 72 °C for 2 min, with a final extension at 72 °C for 7 min. The PCR products were separated by electrophoresis on a 1% agarose gel, stained with ethidium bromide, visualized with a UV transilluminator and photographed. This SCAR marker was then cloned, sequenced and aligned with the sequence of OPW16₉₀₅ bp using ClustalW2 (EMBL-EBI).

Statistical analysis of RAPD data

The reproducible RAPD bands generated by 34 random primers were scored for presence (1) and absence (0) in a binary fashion. Similarity coefficients (S) between isolates were calculated using the formula $S = 2N_{xy}/(N_x + N_y)$, where N_x and N_y are the number of fragments amplified in samples X and Y , respectively, and N_{xy} is the number of bands shared by the two isolates (Nei and Li, 1979). Similarity coefficients were converted to genetic distances (D) using the equation: $D = 1 - S$. A genetic distance matrix was used to construct a dendrogram by the unweighted pair group method with arithmetic averages (UPGMA) using POPGENE 1.32 software (Yeh and Boyle, 1997). The RAPD data were subjected to bootstrap analysis with 1000 replications by using the program WINBOOT and selecting the Dice similarity coefficient (Yap and Nelson, 1996), which is the same as the similarity coefficient of Nei and Li (1979). Discriminant function analysis (DFA) was done with the SPSS/PC+ 11.5 program (M. J. Norusis, SPSS Inc., Chicago). The squared Mahalanobis distance was used to test the group centroid. The Mahalanobis distance is the distance between a case and the centroid (mean of all cases in the group) for each group of the dependent variable in the attributed space ($n - \text{dimensional space defined by } n \text{ variables}$) (Af and Clark, 1984). For DFA, the dependent variable was cocoon weight and four arbitrary groups were used (two each from the low and high cocoon weight groups). The range of cocoon weights for groups 1, 2, 3 and 4 was 7.0-8.5 g, 8.6-9.9 g, 11.0-12.5 g and > 12.6 g, respectively.

The association between RAPD markers and cocoon weight was estimated by stepwise multiple regression analysis in which cocoon weight was treated as the dependent variable and the RAPD markers were treated as independent variables. The analysis was based on the model: $Y = a + b_1m_1 + b_2m_2 + \dots + b_n m_n + d + e$, which related the variation in the dependent variable ($Y = \text{accession means for pupation rate}$) to a linear function for the set of independent variables m_j , the latter representing the RAPD markers. In this equation, b_j corresponds to the partial regression coefficients that specified the empirical relationship between Y and m_j , d represents the accession residual that is left after regression, and e is the random error of Y that includes environmental variation. To select independent variables for the regression equation, F -values with probabilities of 0.045 and 0.099 were used. R^2 denotes the square of R , the multiple regression value. Selected mark-

ers were also tested with linear curve fitting using linear models.

Results

RAPD-PCR of genomic DNA

The screening of genomic DNA from randomly selected tasar silkworms from two weight groups (HCSW and LCSW) and F2 progenies using 34 random primers (Table 1) yielded several reproducible amplicons. The average number of amplicons produced per DNA sample was 2-7 per primer, with sizes that ranged from 300 to 2500 bp. The percentage of polymorphism was 79% and the degree of polymorphism appeared to be independent of the number of markers generated by a particular primer.

Figure 1 shows the UPGMA-based cluster analysis of 18 silkworm samples. The dendrogram separated the HCSW (samples 10 to 18) and LCSW (samples 1 to 9) groups into two major clusters with a significant bootstrap value of 92. In the HCSW group, samples 10, 11, 16, 12, 14 and 13 formed a sub-cluster while samples 15, 18 and 17

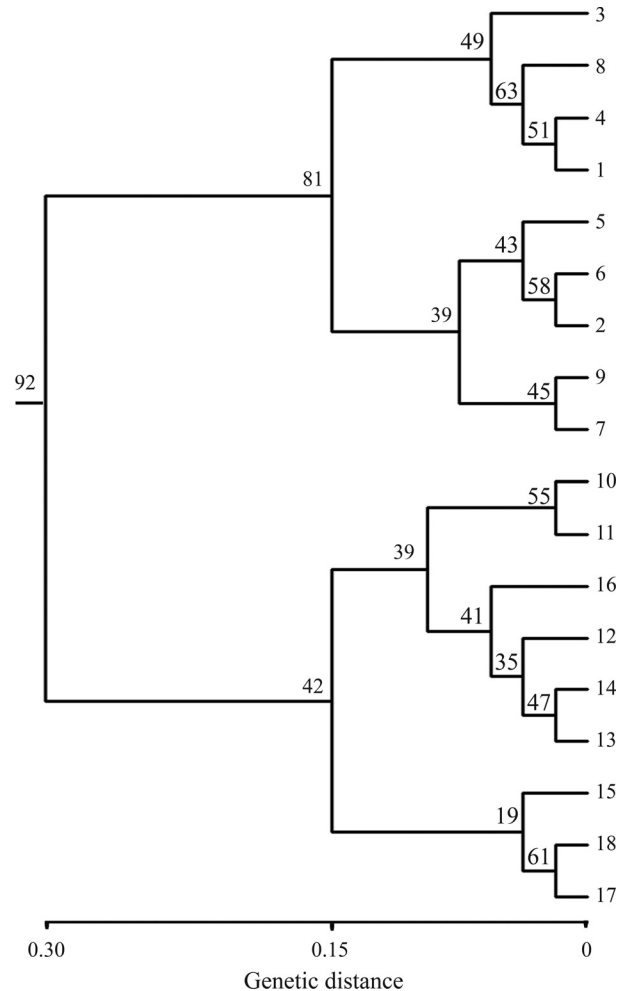

Figure 1 - UPGMA dendrogram drawn using the Nei and Li genetic distance matrix based on RAPD marker data for low (1-9) and high (10-18) cocoon and shell weight groups.

formed another sub-cluster. Similarly, in the LCSW group, samples 3, 8, 4 and 1 formed a sub-cluster and samples 5, 6, 7, 9 and 2 formed another sub-cluster.

For DFA, the dependent variable was cocoon weight and four arbitrary groups were defined (two each from the low and high cocoon weight groups). The mean range of cocoon weight for groups 1, 2, 3 and 4 was 7.0-8.5 g, 8.6-9.9 g, 11.0-12.5 g and >12.6 g, respectively.

A matrix plot of discriminant function 1 versus function 2 revealed separation of the weight groups (Figure 2). The HCSW group occupied a position from 2.0 to 9.0 on the x-axis and from -3.0 to 2.1 on the y-axis of the plot. In the dendrogram, this group also formed clusters clearly separated from the LCSW group. In the LCSW group, samples 2, 5, 6, 7 and 9 occupied a position from -5.8 to -8.0 on the x-axis and from 2.0 to 5.0 on the y-axis. In the dendrogram, this group also formed a major cluster. In addition, samples 1, 3, 4 and 8 of the LCSW group occupied positions from -5.0 to -9.0 on the x-axis and from -5.9 to -3.2 on the y-axis. In the dendrogram, these samples also formed a separate cluster. DFA identified two functions, the first of which explained 78.9% of the variance. The canonical correlation value was estimated to be 0.991 (Wilk's $\lambda = 0.001$; $\chi^2 = 87.255$, $p < 0.001$). The results of DFA thus supported the UPGMA-based cluster analysis.

Association of RAPD markers with quantitative traits

Stepwise multiple regression analysis (MRA) was used to assess the relationship (association) of DNA markers with yield parameters such as cocoon weight and shell weight. In MRA, each variable is entered sequentially and its value assessed. If adding the variable contributes to the model then it is retained and all other variables in the model are re-tested to determine whether they still contribute to the success of the model. In this case, R^2 is interpreted for the overall relationship at the step or model when the last statistically significant variable was entered. Variables that no longer make a significant contribution are removed. This method ensures that the smallest possible set of predictor variables is included in the steps or models. Table 2

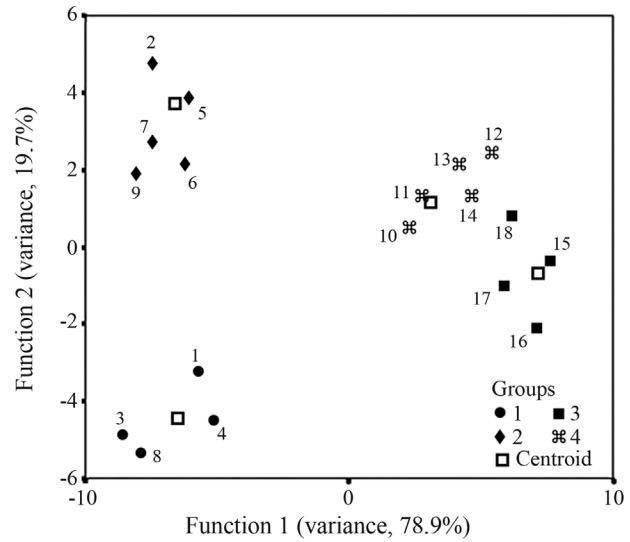

Figure 2 - Discriminant function analysis plot for the HCSW and LCSW groups. Group 1: 7.0-8.5 g, group 2: 8.6-9.9 g, group 3: 11.0-12.5 g and group 4: >12.6 g.

provides the summary statistics of MRA for five identified markers. In the first model, MRA identified OPW16-2 which contributes to 61.2% of the total variance ($R = 0.782$, $p < 0.0001$); the standardized β coefficient was also very high (0.757). In the next step or model 2, an additional marker band (OPW18-5) that contributed a further 16.1% of variance was identified. Subsequent steps identified three additional markers (OPC9-3, HAP03-6 and OPAJ08-4) and the final step (model 5) accounted for 93.7% of the variance ($R^2 = 0.937$). The high regression coefficients (R) with significant F values substantiated the strength of the association of these markers with cocoon weight and shell weight. The primer OPW16 consistently amplified a single, intense band of ~900 bp (designated as OPW16_{905 bp}) along with other bands of different sizes in all individuals of the HCSW group. The scatter diagram of the MRA plot (Figure 3) showed a significant, positive linear relationship between the OPW16-2 marker (*i.e.*, OPW16_{905 bp}) and the samples of the HCSW and LCSW groups.

Table 2 - Summary statistics for multiple regression analysis (MRA) with RAPD marker data in which cocoon weight was the dependable variable.

Model	R	R ²	Standard error	Change statistics		
				Change in R ²	Change in F	p value for the change in F
1	0.782 ^a	0.612	1.740	0.612	25.242	0.000
2	0.879 ^b	0.774	1.373	0.161	10.693	0.005
3	0.918 ^c	0.842	1.187	0.068	6.062	0.027
4	0.951 ^d	0.904	0.962	0.062	8.306	0.013
5	0.968 ^e	0.937	0.809	0.033	6.380	0.027

^aPredictors: (Constant), OPW16-2; ^bPredictors: (Constant), OPW16-2 and OPW18-5; ^cPredictors: (Constant), OPW16-2, OPW18-5 and OPC9-3; ^dPredictors: (Constant), OPW16-2, OPW18-5, OPC9-3 and HAP03-6; ^ePredictors: (Constant), OPW16-2, OPW18-5, OPC9-3, HAP03-6 and OPAJ08-4.

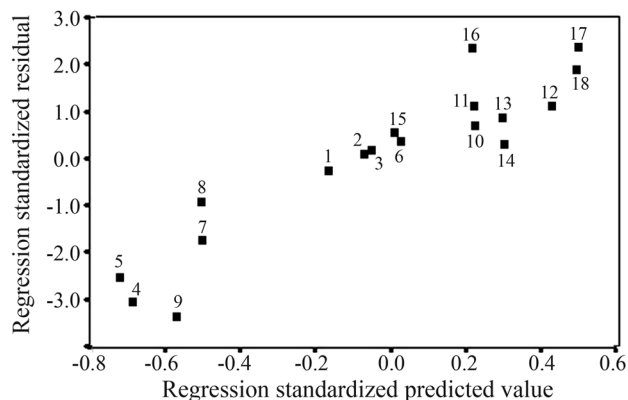

Figure 3 - Multiple regression analysis of the marker OPW16_{905 bp} with cocoon weight (CW) as the dependable variable. 1-9 and 10-18 represent the low and high cocoon weight groups, respectively.

Cloning and characterization of HCSW-specific RAPD fragment

Electrophoretic analysis of the PCR products amplified by primer OPW 16 revealed 152 amplicons of 13 sizes. Of these amplicons, 72 belonged to the HCSW group, 51 to the LCSW group and 29 to F₂ progeny (HCSW x LCSW) (Figure 4). The amplicon sizes varied from 500 to <2500 bp and the observed polymorphism in the HCSW and LCSW groups and F₂ progeny was 86.1%, 84.3% and 44.8%, respectively (Table 3). A single, intense band of ~900 bp was consistently amplified in all individuals of the HCSW group and in 50% of the F₂ progeny (HCSW x LCSW) but in none of the LCSW group, except for sample 19, in which there was non-specific amplification of a band with a similar size (not amplified by the SCAR primer). Cloning and sequencing of this HCSW-specific RAPD fragment

showed that it consisted of 905 nucleotides containing the OPW16 sequence at its 5' and 3' ends (GenBank accession number: JQ710731). BLAST searches of the nucleotide sequences in GenBank showed that 134 nucleotides of this fragment (nucleotides 628 to 762) shared 88% identity with the *A. mylitta* Bmc1/Yamato-like retroposon sequence, with an E value of 3e-34.

Conversion of OPW 16_{905 bp} into a SCAR marker

To generate a stable HCSW-specific diagnostic SCAR marker, two primers (*AmSCAR-Forward* and *AmSCAR-Reverse*) for PCR were synthesized based on the OPW16_{905 bp} sequence. As shown in Figure 5, a single specific band of ~800 bp was amplified only in the HCSW group and in 50% of the F₂ progeny, thus indicating inheritance of this marker. Cloning and sequencing of this SCAR marker (826 bp) revealed a complete match with the original sequence of the OPW16_{905 bp} marker. The lack of this specific amplicon in the LCSW group indicated the efficacy of this marker in distinguishing the HCSW group from the others.

Discussion

Among commercial silk producing lepidopterans, *A. mylitta* has a special status, not only for its unique silk but also because of its contribution to the rural economy in India. In addition to its common use as a natural filament, two proteins produced by this silkworm (fibroin and sericin) have recently been shown to be useful biomaterials as a matrix for culturing cells (Acharya *et al.*, 2009). However, silk production by this silkworm is hampered by a lack of high yield breeds or hybrids, hence the need to increase productivity through modern molecular tools.

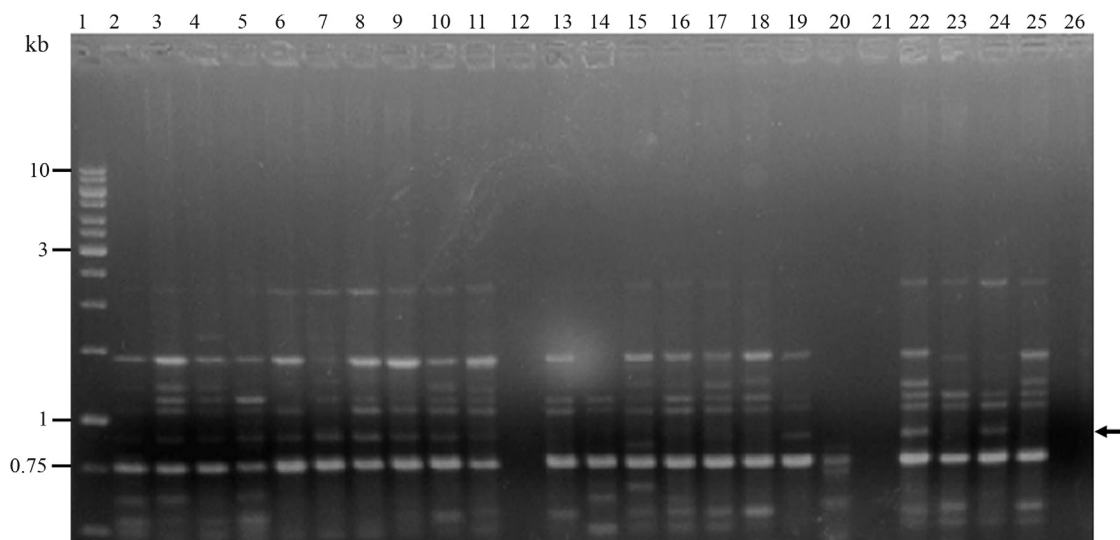
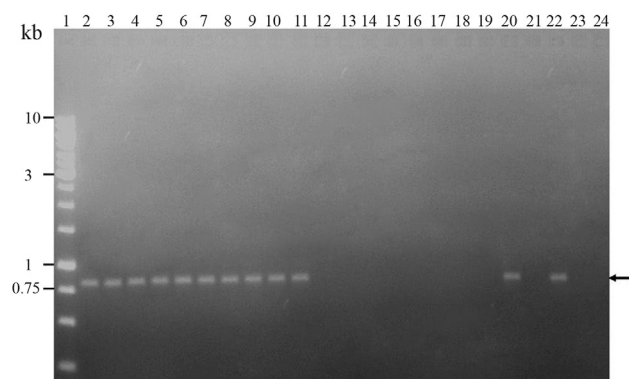

Figure 4 - Analysis of RAPD amplicons (amplified with the primer OPW16) by electrophoresis in a 1.5% agarose gel. Lane 1: molecular weight marker (1 kb DNA ladder; Fermentas), lanes 2-11: HCSW group, lanes 13-20: LCSW group, lanes 22-25: F₂ group (HCSW x LCSW) and lane 26: negative control. The arrow indicates the amplification of a specific band (~900 bp).

Table 3 - Polymorphic DNA bands detected in HCSW, LCSW and F2 progenies by RAPD using the PCR primers OPW16, OPW18, OPC9, HAP03 and OPAJ08.

Primer	HCSW		LCSW		F2 progeny	
	Total number of bands	Polymorphism (%)	Total number of bands	Polymorphism (%)	Total number of bands	Polymorphism (%)
OPW16	72	86.11	51	84.31	29	44.83
OPW18	36	100	27	100	12	33.33
OPC9	37	75.7	55	83.64	31	74.2
HAP03	61	55.74	68	60.3	29	58.62
OPAJ08	56	83.92	67	86.57	40	50

**Figure 5** - Analysis of the PCR amplicons of a SCAR marker by agarose gel electrophoresis. Lane 1: molecular weight marker (1 kb DNA ladder; Fermentas); lanes 2-11: HCSW group, lanes 12-19: LCSW group, lanes 20-23: F2 progeny group (HCSW X LCSW) and lane 24: negative control. The arrow indicates the amplification of a specific band.

The use of molecular markers to select parents and hybrids with desirable traits at the early stages of breeding programs is gradually increasing. Virk *et al.* (1996) strongly advocated the use of a regression model to identify the best genotype within a segregating population or in a pool of land races/varieties. In the silkworm *B. mori*, MRA has been used to identify molecular markers associated with yield traits (Sethuraman *et al.*, 2002; Chatterjee and Pradeep, 2003; Chatterjee and Mohandas, 2003; Mohandas *et al.*, 2004).

RAPD analysis provides wider coverage of the genome than microsatellite analysis, particularly for species such as *A. mylitta*, for which there is still no complete genome map (Gu *et al.*, 1998). Jain *et al.* (2010) reviewed the use of RAPD and SCAR markers for analyzing insect-plant interactions, insect-pathogen interactions and studies of genetic diversity. In the present work, genomic DNA from selected individuals of the HCSW and LCSW groups of ecorace Daba and their F2 progeny (HCSW x LCSW) were amplified using random primers. The high level of polymorphism and heterozygosity observed in these samples corroborated the findings of previous studies (Kar *et al.*, 2005; Saha and Kundu, 2006; Saha *et al.*, 2008), and the

HCSW group formed a separate cluster in the UPGMA dendrogram.

In the wild, *A. mylitta* rarely undergoes inbreeding and yield traits such as cocoon weight, larval weight and shell weight are likely to be under polygenic control (Shibukawa *et al.*, 1986; Rao *et al.*, 1991). Consequently, bulk segregation analysis (Michaelmore *et al.*, 1991) may not be ideal for detecting marker genes in this highly heterogeneous insect species. However, the selection of a group of markers, together with statistical approaches such as MRA and DFA, may be useful in explaining the polygenic control of these characters. For this reason, we used MRA and DFA to identify markers in selected individual pupae that differed in cocoon weight and shell weight. DFA showed that the distribution of the HCSW group differed from that of the LCSW group. In addition, OPW16-2 and four other associated RAPD markers (OPW18-5, OPC9-3, HAP03-6 and OPAJ08-4) that showed a significant positive association with cocoon weight and shell weight were identified by MRA. High regression coefficients (R) with significant F values further substantiated the association of these markers with cocoon weight and shell weight. Together, these findings indicate that all of these RAPD markers can be used to screen parental stock for breeding purposes.

A specific marker (OPW16_{905 bp}) was identified and showed a positive, significant association with the HCSW group, as confirmed by MRA and DFA. The inheritance was also confirmed in F₂ progeny. Cloning and sequencing of this marker and subsequent BLAST analysis revealed that this sequence shared 88% identity with the Bmc-1/Yamato-like retroposon sequence of *A. mylitta*. The presence of this RAPD fragment was further verified by developing a specific diagnostic SCAR marker. Only a single band was amplified in all individuals of the HCSW group and in 50% of the F₂ progeny, indicating that this marker may be located in a single locus. SCAR markers are high fidelity molecular DNA markers (Michaelmore *et al.*, 1991; Nair *et al.*, 1995, 1996) that have a vital role in determining the configuration of RAPD markers; the codominance of SCAR markers overcomes some of the limitations of RAPD markers. SCAR markers have been developed to detect *Helicoverpa armigera* (Agusti *et al.*, 1999) and the

whitefly, *Trialeurodes vaporariorum* (Agusti *et al.*, 2000) in the gut of the predator *Dicyphus tamaninii*. Simon *et al.* (1999) used RAPD-based SCAR markers to study differences in the breeding system of segregating and natural populations of the cereal aphid *Rhopalosiphum padi* L. Filho *et al.* (2002) developed SCAR markers from three RAPD markers in soybean (*Glycine max*) and showed that they tagged the resistance gene against leaf spot disease caused by the fungus *Cercospora sojina*. Rugienius *et al.* (2006) constructed SCAR markers based upon the RAPD marker OPO-16C linked to the susceptible allele of the red stele (*Phytophthora fragariae*) resistance gene *Rpfl* in strawberry. These authors used this SCAR marker to identify resistant varieties of strawberry. RAPD SCAR markers have also been successfully developed and used to identify some ecoraces of *A. mylitta* (Saha *et al.*, 2008).

In the present study, the RAPD marker OPW 16₉₀₅ bp and the SCAR marker SCOPW16₈₂₆ bp, which are specific for cocoon weight and shell weight, were found to be highly reproducible and can therefore be used to analyze the inheritance patterns of these yield traits. This is the first report on the development of SCAR marker that can be used to identify specific yield traits in *A. mylitta*. The ability of OPW16₉₀₅ bp and SCOPW16₈₂₆ bp to discriminate between the HCSW and LCSW groups makes them very useful diagnostic markers for these individuals and potential molecular tools for improving the yield of tasar silk and for marker-assisted selection aimed at developing highly productive *A. mylitta*. Further experiments are required to identify the genes located close to these markers

Acknowledgments

The authors thank Dr. B.C. Prasad (Director, Central Tasar Research and Training Institute, Ranchi, India) for help with this work. This work was supported by the Central Silk Board, Ministry of Textiles, Government of India (grant no. AIG-4669).

References

- Acharya C, Ghosh SK and Kundu SC (2009) Silk fibroin film from non-mulberry tropical tasar silkworms: A novel substrate for *in vitro* fibroblast culture. *Acta Biomater* 5:429-436.
- Af AA and Clark V (1984) *Computer-Aided Multivariate Analysis*. Van Nostrand Reinhold, New York, 458 pp.
- Agusti N, DeVicent MC and Gabarra R (1999) Development of sequence amplified characterized regions (SCAR) markers of *Helicoverpa armigera*: A new polymerase chain reaction-based technique for predator gut analysis. *Mol Ecol* 8:1467-1474.
- Agusti N, DeVicent MC and Gabarra R (2000) Developing SCAR markers to study predation on *Trialeurodes vaporariorum*. *Insect Mol Biol* 9:263-268.
- Chatterjee SN and Mohandas TP (2003) Identification of ISSR markers associated with productivity traits in silkworm, *Bombyx mori* L. *Genome* 46:438-447.
- Chatterjee SN and Pradeep AR (2003) Molecular markers (RAPD) associated with growth, yield and origin of the silkworm, *Bombyx mori* L. in India. *Russ J Genet* 39:1365-1377.
- Doira H (1978) Genetic stocks of the silkworm. In: Tazima Y (ed) *The Silkworm, an Important Laboratory Tool*. Kodansha Ltd., Tokyo, pp 53-81.
- Filho SM, Sedyama CS, Moreira MA and de Barros EG (2002) RAPD and SCAR markers linked to resistance to frogeye leaf spot in soybean. *Genet Mol Biol* 25:317-321.
- Gu W, Acland GM, Langston AA, Ostrander EA, Aguirre GD and Ray K (1998) Identification of a RAPD marker linked to progressive rod-cone degeneration in dogs. *Mamm Genome* 9:740-744.
- Inoue E, Kasumib M, Sakumac F, Anzaid H, Amanoa K and Haraa H (2006) Identification of RAPD marker linked to fruit skin color in Japanese pear (*Pyrus pyrifolia* Nakai). *Sci Hortic (Amsterdam)* 107:254-258.
- Jain SK, Neekhra B, Pandey D and Jain K (2010) RAPD marker system in insect study: A review. *Indian J Biotech* 9:7-12.
- Kar PK, Vijayan K, Mohandas TP, Nair CV, Saratchandra B and Thangavelu K (2005) Genetic variability and genetic structure of wild and semi-domestic populations of tasar silkworm (*Antheraea mylitta*) ecorace Daba as revealed through ISSR markers. *Genetica* 125:173-183.
- Keisuke M, Tetsuya I, Toshio Y, Eiji O and Wajirou H (2007) Genetic mapping of a food preference gene in the silkworm, *Bombyx mori*, using restriction fragment length polymorphisms (RFLPs). *Genes Genet Syst* 82:249-256.
- Martin GB, Williams JGK and Tanksley SD (1991) Rapid identification of markers linked to a *Pseudomonas* resistance gene in tomato by using random primers and near-isogenic lines. *Proc Natl Acad Sci USA* 88:2336-2340.
- McCouch SR, Chen X, Panaud O, Temnykh S, Xu Y, Cho YG, Huang N, Ishii T and Blair M (1997) Microsatellite marker development, mapping and application in rice genetics and breeding. *Plant Mol Biol* 35:89-99.
- Michaelmore RW, Paran I and Kesseli RV (1991) Identification of markers linked to disease resistance genes by bulked segregant analysis: A rapid method to detect markers in specific genomic regions using segregating populations. *Proc Natl Acad Sci USA* 88:9828-9832.
- Mohandas TP, Sethuraman BN, Saratchandra B and Chatterjee SN (2004) Molecular genetic approach for identifying markers associated with yield traits in the silkworm, *Bombyx mori* using RFLP-STS primers. *Genetica* 122:185-197.
- Nagaraju J and Singh L (1997) Assessment of genetic diversity by DNA profiling and its significance in silkworm *Bombyx mori*. *Electrophoresis* 18:1676-1681.
- Nair S, Bentur JS, Prasad Rao U and Mohan M (1995) DNA markers tightly linked to a gall midge resistance gene (*Gm2*) are potentially useful for marker-aided selection in rice breeding. *Theor Appl Genet* 91:68-73.
- Nair S, Kumar A, Srivastava MN and Mohan M (1996) PCR-based DNA markers linked to a gall midge resistance gene, *Gm4t*, has potential for marker-aided selection in rice. *Theor Appl Genet* 92:660-665.
- Nei M and Li WH (1979) Mathematical model for studying genetic variation in terms of restriction endonucleases. *Proc Natl Acad Sci USA* 76:5269-5273.

- Proboon A, Shimada T, Fujiwara H and Kobayashi M (1995) Linkage map of random amplified polymorphic DNA (RAPDs) in the silkworm, *Bombyx mori*. *Genet Res* 66:1-7.
- Rao GS, Das SK and Das NK (1991) Genetic divergence among fifteen multivoltine genetic stocks of silkworm (*Bombyx mori* L). *Indian J Seric* 30:72-74.
- Rugienius R, Siksnianas T, Stanys V, Gelvonauskienene D and Bedokas V (2006) Use of RAPD and SCAR markers for identification of genotypes carrying red stele (*Phytophthora fragariae*) resistance gene *Rpf1*. *Agron Res* 4:335-339.
- Saha M and Kundu SC (2006) Molecular identification of tropical tasar silkworm (*Antheraea mylitta*) ecoraces with RAPD and SCAR markers. *Biochem Genet* 44:75-88.
- Saha M, Mahendran B and Kundu SC (2008) Development of random amplified polymorphic DNA markers for tropical tasar silkworm *Antheraea mylitta*. *J Econ Entomol* 101:1176-1182.
- Sambrook J and Russel DW (2003) *Molecular Cloning: A Laboratory Manual*. Cold Spring Harbor Laboratory Press, Cold Spring Harbor, New York.
- Sethuraman BN, Mohandas TP and Chatterjee SN (2002) DNA fingerprinting with homologous multilocus probes and search for DNA markers associated with yield attributes in silkworm, *Bombyx mori*. *Eur J Entomol* 99:267-276.
- Shi J, Heckel DG and Goldsmith MR (1995) A genetic linkage map for the domesticated silkworm, *Bombyx mori*, based on restriction fragment length polymorphisms. *Genet Res* 66:109-126.
- Shibukawa A, Eguchi R, Shimajaki A and Ichida M (1986) Studies on the cocoon quality of the silkworm stock cultures of the sericulture experiment station. *Tech Bull Seric Exp* 129:1-34.
- Simon JC, Leterme N and Latorre A (1999) Molecular markers linked to breeding system differences in segregating and natural populations of the cereal aphid *Rhopalosiphum padi* L. *Mol Ecol* 8:965-973.
- Suryanarayana N and Srivastava AK (2005) *Monograph on Tropical Tasar Silkworm*. Central Tasar Research and Training Institute, Ranchi, 87 pp.
- Tanksley SD, Young ND, Paterson AH and Bonier Bale MW (1989) RFLP mapping in plant breeding. New tools for an old science. *Bio-Technology* 7:257-264.
- Tazima Y (1964) *The Genetics of Silkworm*. Logos Press, New York, 253 pp.
- Virk PS, Ford-Lloyd BV, Jackson MT, Pooni HS, Clemeno TP and Newbury HJ (1996) Predicting quantitative variation within rice germplasm using molecular markers. *Heredity* 76:296-304.
- Williams JGK, Kubelik AR, Livak KJ, Rafalski JA and Tingey SV (1990) DNA polymorphisms amplified by arbitrary primers are useful genetic markers. *Nucleic Acids Res* 18:6531-6535.
- Yap IV and Nelson RJ (1996) Winboot: A program for performing bootstrap analysis of binary data to determine the confidence limits of UPGMA-based dendrograms. *Int Rice Res Inst Discussion Paper* 14:1-22.
- Yeh FC and Boyle TJB (1997) Population genetic analysis of co-dominant and dominant markers and quantitative traits. *Belg J Bot* 129:157-163.

Associate Editor: Louis Bernard Klackzo

License information: This is an open-access article distributed under the terms of the Creative Commons Attribution License, which permits unrestricted use, distribution, and reproduction in any medium, provided the original work is properly cited.